

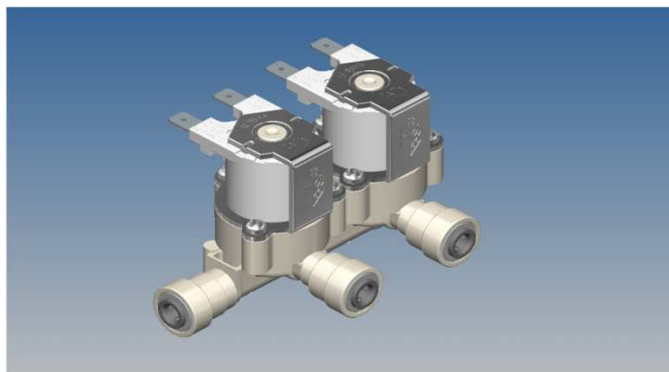

Rpe s.r.l.
Via S. Ambrogio, 3
22070 Carbonate (CO)
Italy
Tel. +39 0331 83.25.15
Fax +39 0331 83.25.01
www.rpesrl.it

Elettrovalvola Serie R Dispenser

R Dispenser 237 128



CLASSIFICAZIONE

Tipologia	Doppia
Geometria	180°

CARATTERISTICHE DI LAVORO

Pressione di esercizio	0,2 ÷ 10 bar
Temperatura ambiente	0 ÷ 60° C
Temperatura fluido	25° C; 60° C; 90° C
Ciclo di lavoro	ED 100%; ED 60%(90°)
Direzione del fluido	Unidirezionale
Diametro di passaggio	DN 10 mm
Comando	Bistabile; NA; NC

CARATTERISTICHE FISICHE

Corpo valvola	PA 66 30% fibra vetro
Membrana e guarnizioni	NBR (buna)
Nucleo	Acciaio Inox
Molla	Acciaio Inox
Assemblaggio	Con viti ispezionabile

CONNESSIONI IDRAULICHE

Conessioni in ingresso	2 IN Attacco rapido JG 1/4
Conessioni in uscita	1 OUT Attacco rapido JG 1/4

CONNESSIONI ELETTRICHE

Conness elettriche 1	Faston Maschio 6,3x0,8 mm
Conness elettriche 2	
Conness elettriche 3	

APPLICAZIONI

Ovunque necessario il controllo automatico dell'acqua. Carico H2O caldaie piccolo elettrodomestico e impianti filtrazione, frigoriferi, macchine ghiaccio, distributori acqua, forni, rubinetti, idromassaggi, Macchine caffè, irrigazione e idropulitrici.

CLASSIFICATION

Type	Double
Geometry	180°

WORKING SPECIFICATIONS

Working pressure	0,2 ÷ 10 bar
Room temperature	0 ÷ 60° C
Fluid temperature	25° C; 60° C; 90° C
Duty cycle	ED 100%; ED 60%(90°)
Flow direction	Unidirectional
Nominal diameter	DN 10 mm
Control	Latching; NC; NO

PHYSICAL SPECIFICATIONS

Valve body	PA 66 30% fiber glass
Diaphragms gasket	NBR (buna)
Core	Stainless steel
Spring	Stainless steel
Assembly	With screws for inspection

HYDRAULIC CONNECTIONS

Inlet	2 IN Quick connection JG 1/4
Outlet	1 OUT Quick connection JG 1/4

ELECTRICAL CONNECTIONS

Electric connect 1	Male Faston 6,3x0,8 mm
Electric connect 2	
Electric connect 3	

APPLICATIONS

Wherever automatic water control is needed. Water filling in small boiler and in filtration plants, refrigerators, ice machinws, water dispensers, industrial ovens, taps, hydromassage, coffee makers, irrigation, high pressure jet machine

MARCHI E APPROVAZIONI / MARKS AND CERTIFICATIONS



1 2 3 4 5 6 7 8

A

John Guest Ø1/4" (x2)

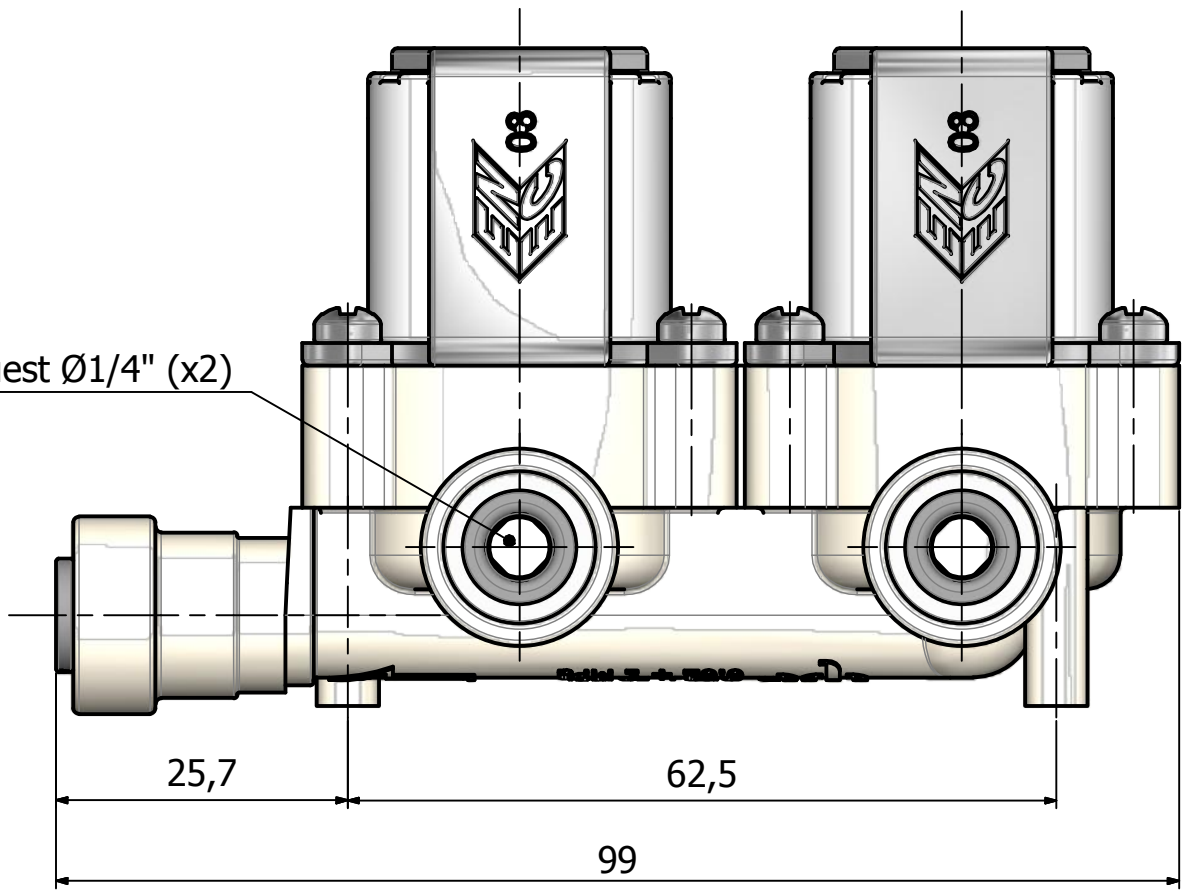

B

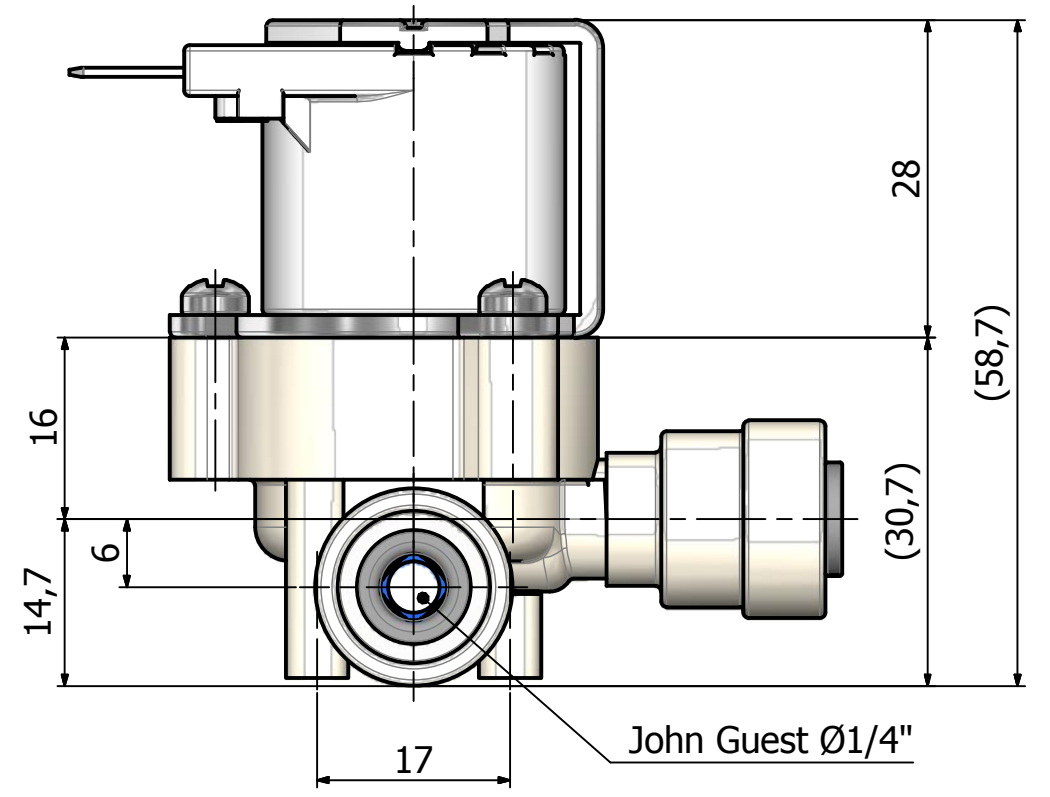

A

B

C

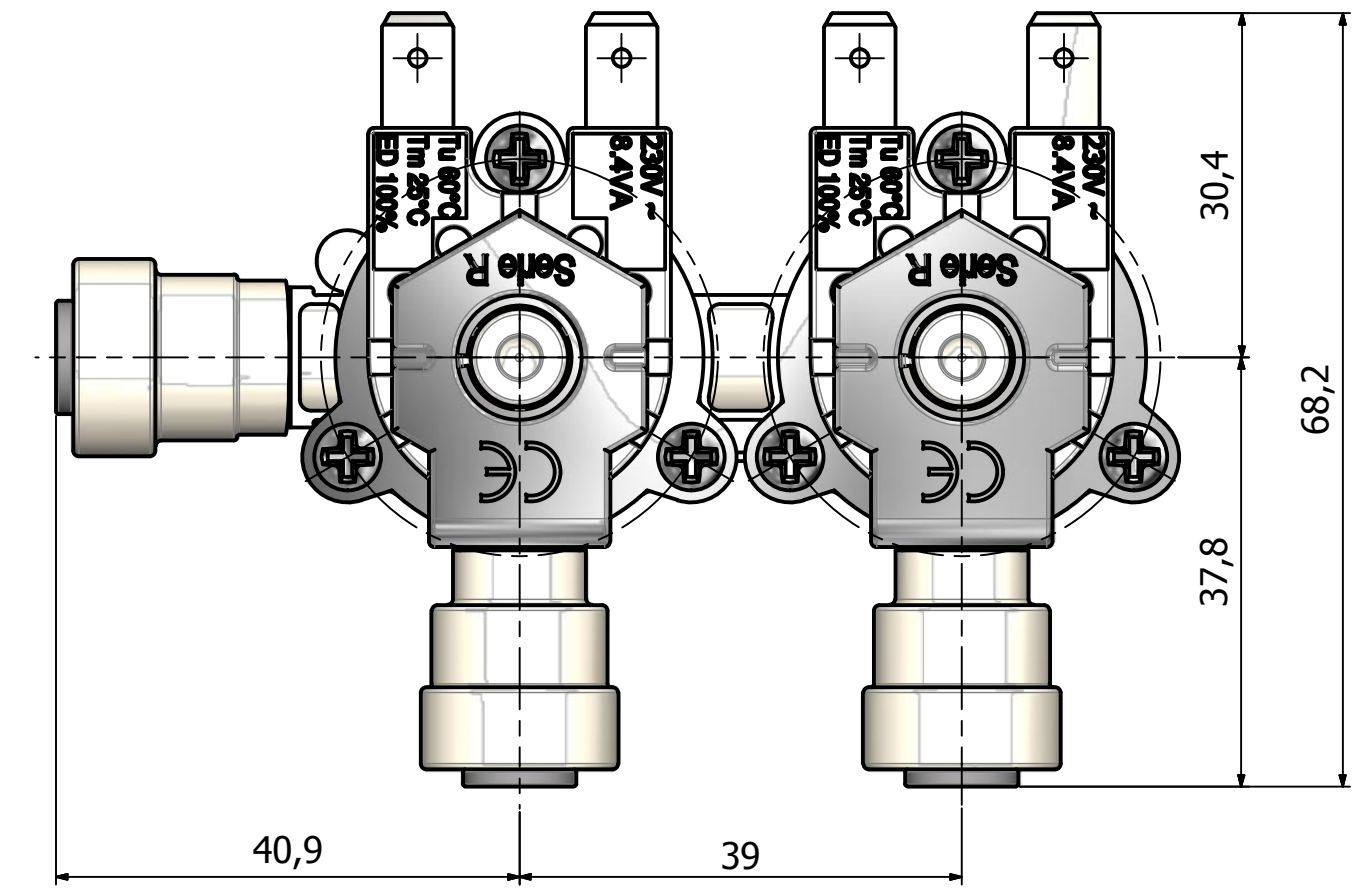

D

C

D

 <p>R Dispenser 237 128</p> <p>ELETTROVALVOLE IDRAULICHE SOLENOID VALVES</p> <p>Tel.: +39 0331 832515 Fax.: +39 0331 832501 www.rpesrl.it - info@rpesrl.it</p>	Serie:		Data:
	R		20/12/2016
		Revisione:	0

1 2 3 4 5 6 7 8